

DEVELOPING A LIVING, BREATHING T-SHIRT (CAP 2011 invited presentation)

Maksim Skorobogatiy,
Professor and Canada Research Chair,
École Polytechnique de Montréal, University of Montreal, Canada
www.photonics.phys.polymtl.ca

Joanna Berzowska,
Professor, Hexagram research center, Concordia University and XS Labs

<http://www.xslabs.net/karma-chameleon/>

Smart textiles under development in our group

- Photonic textiles
- Actuator/sensor textiles
- Energy storage textiles

Smart textiles under development in our group

- Photonic textiles
- Actuator/sensor textiles
- Energy storage textiles

Photonic textiles

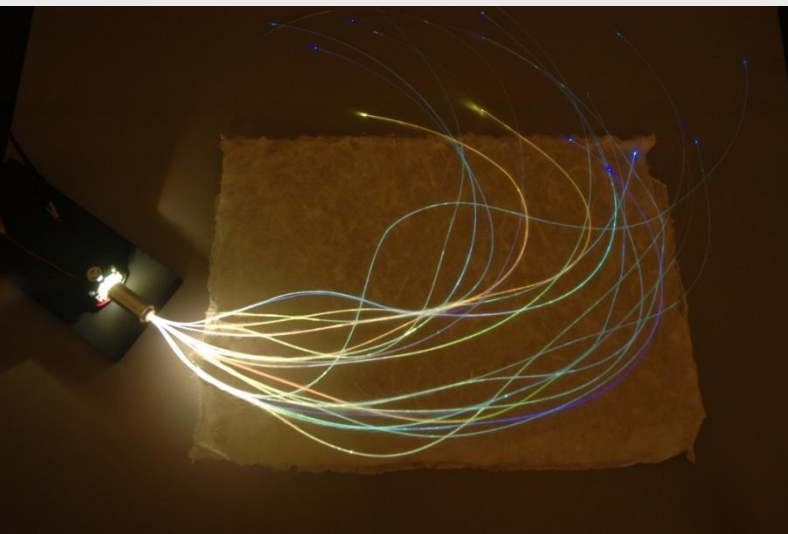
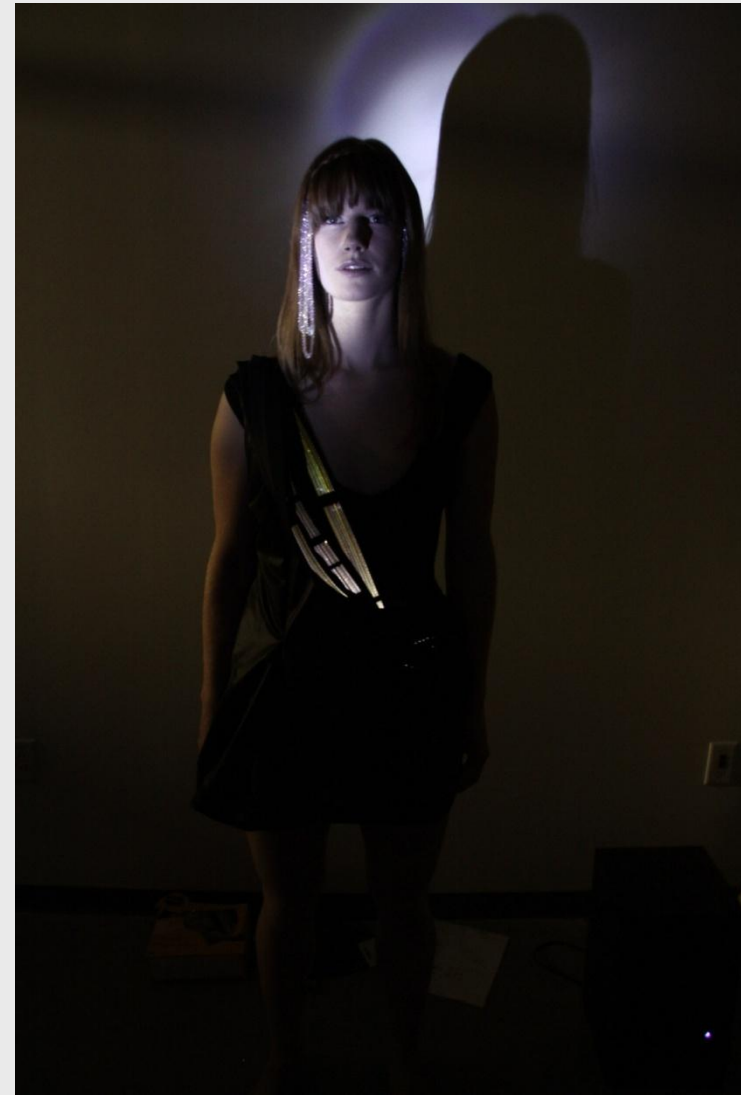
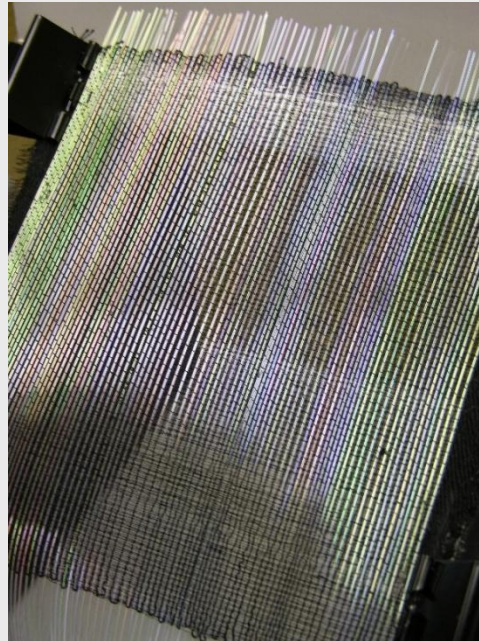

Total Internal Reflection (conventional) optical fibers re-cap

Very efficient guiding in the fiber core, almost no light escapes sideways

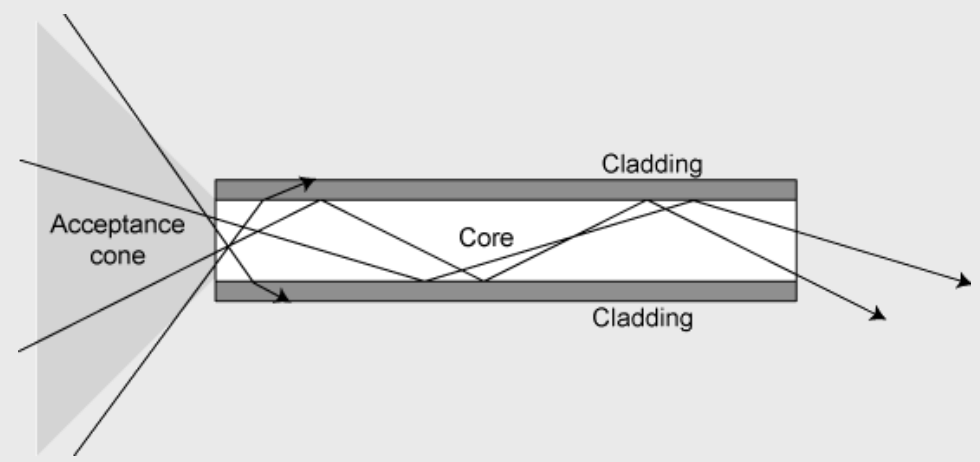
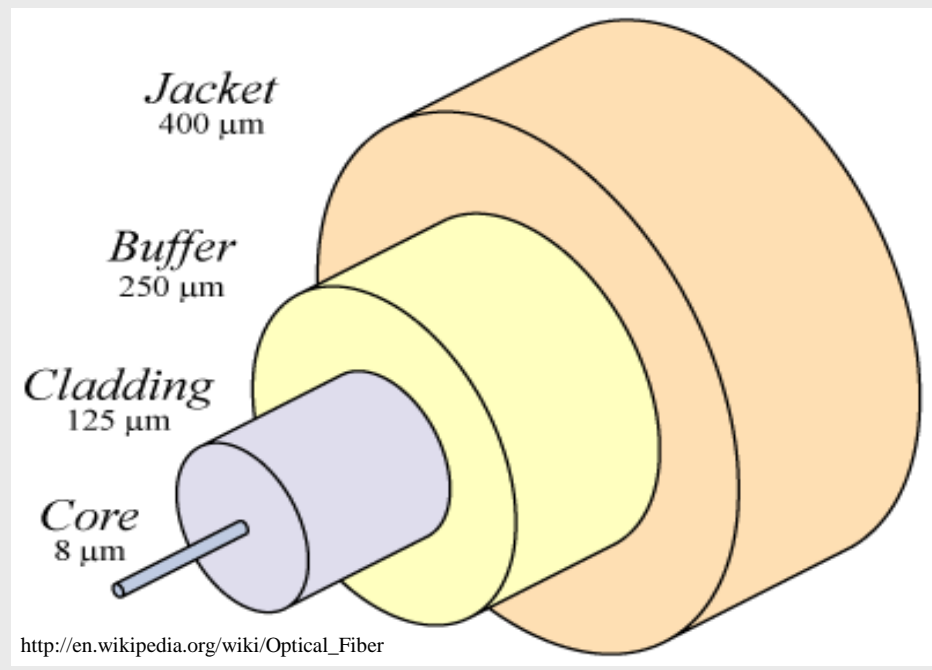
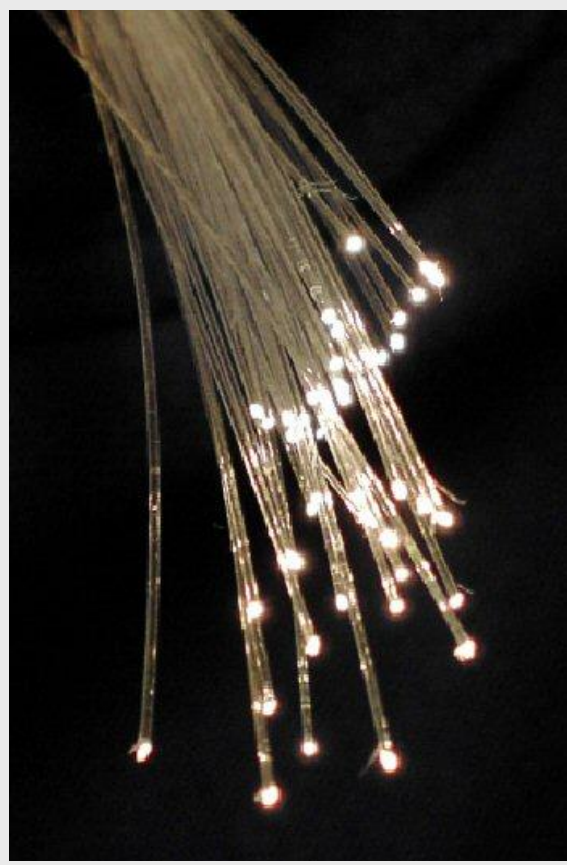

Luminex

Luminex has created fabrics that incorporate woven optical fibers for decorative effect.

The optic fibers are woven into a synthetic fiber, the ends of which are bundled together to a point from which LED light is transmitted through filaments.

These emit light along the length as well as the filaments ends.



'ColorFull' plastic fibers for advanced textiles and short-range communications

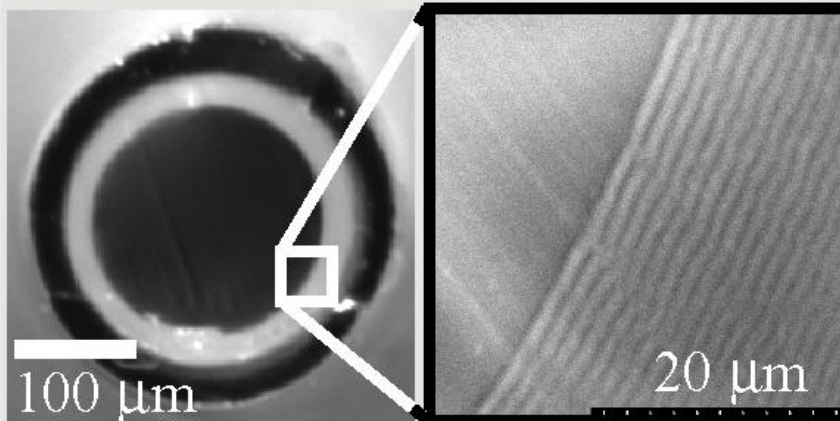
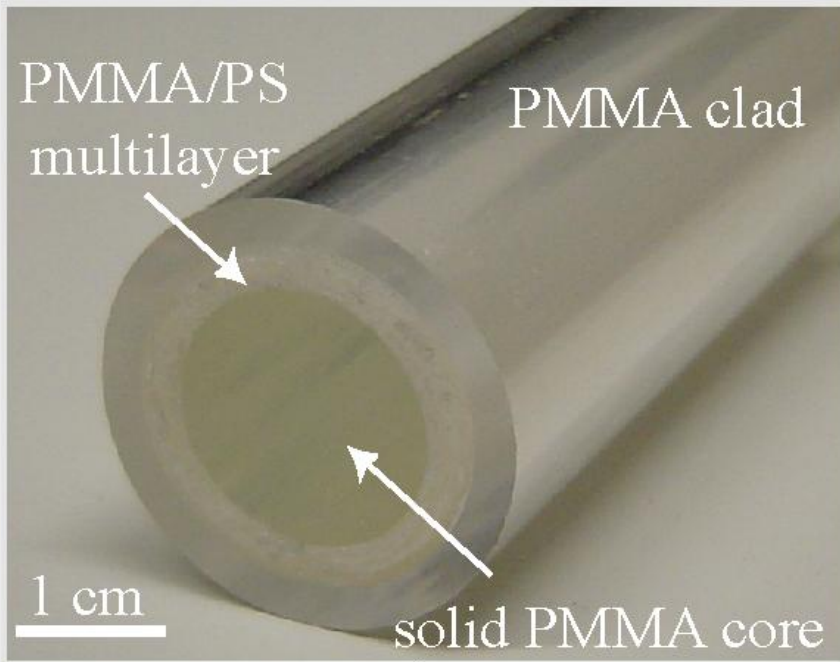

Reflection of ambient light

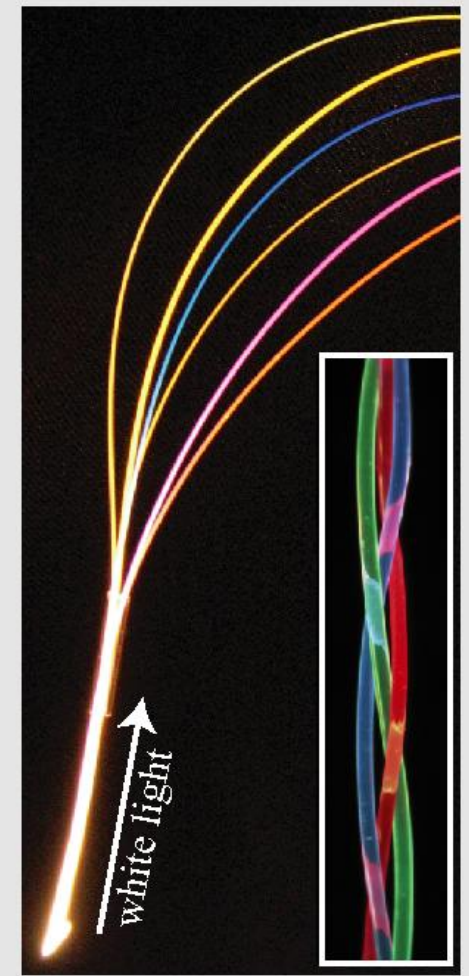

Emission of guided light

Fiber color in reflection (no guided light)

Dielectric multilayer “mirrors” have different colors when looked at different angles

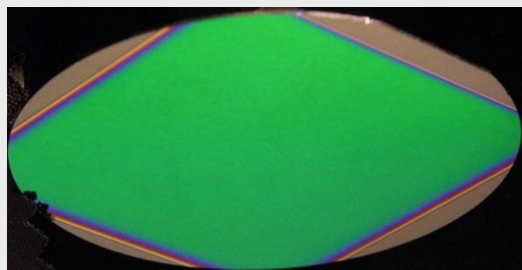
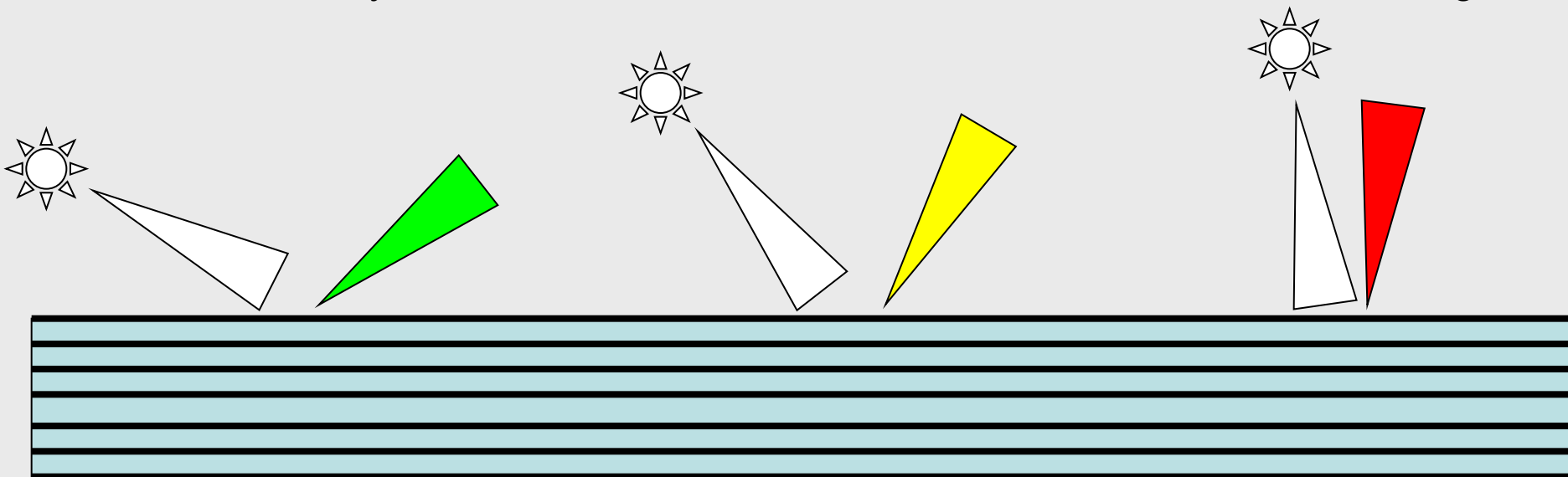

Fiber guiding regime

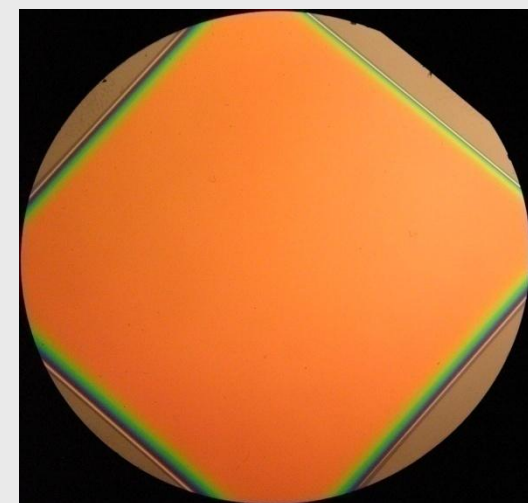
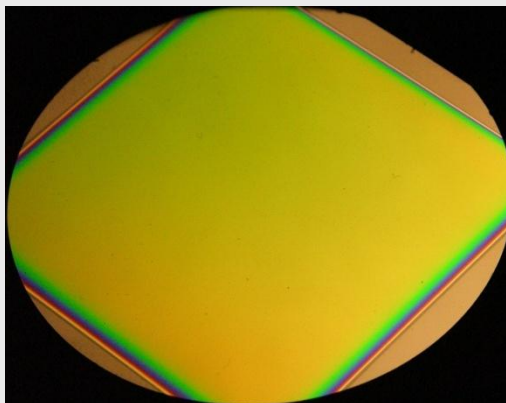

Outside reflection regime

PBG fiber bundles application in colorful illumination

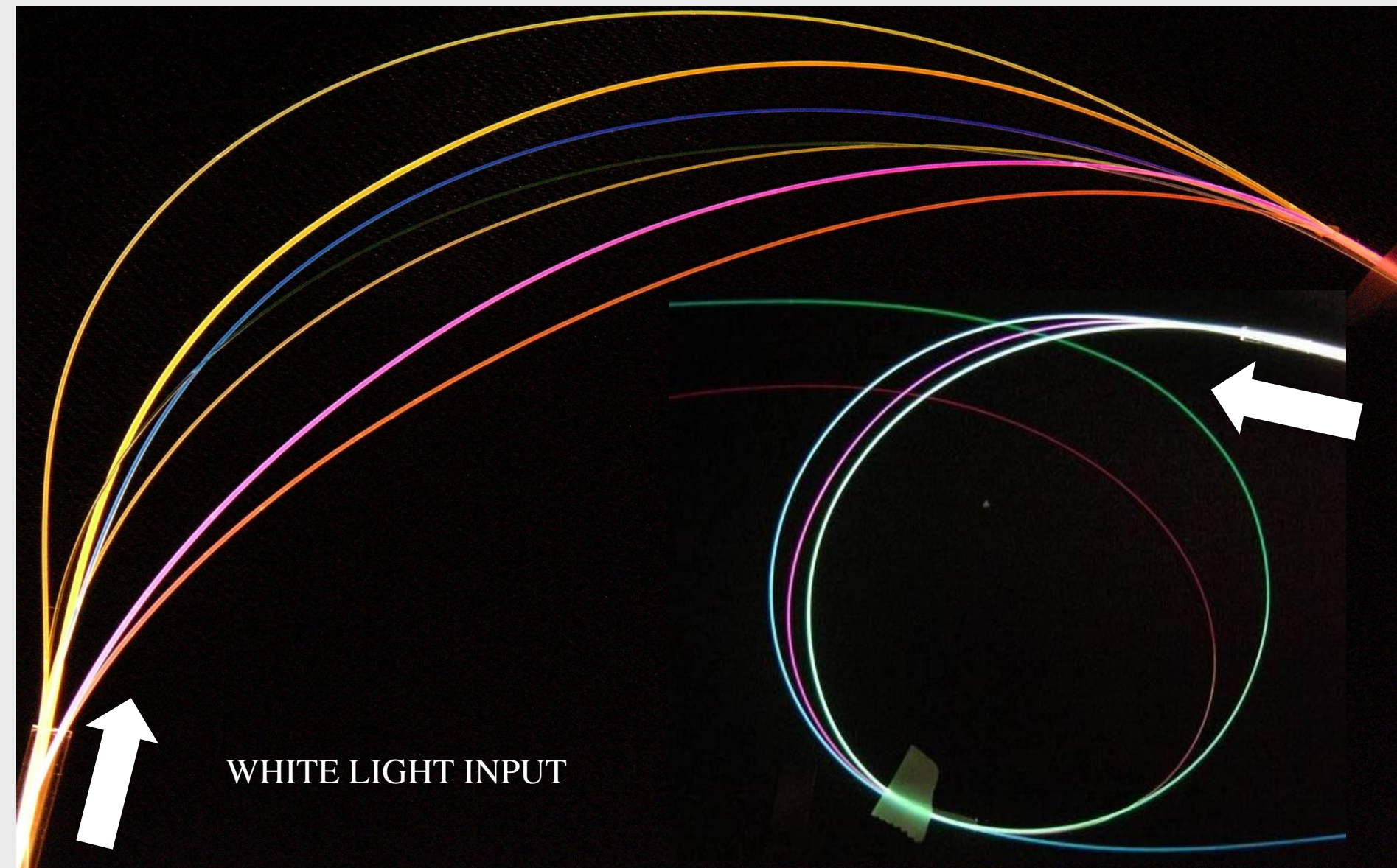

Why photonic crystal fibers are colored?

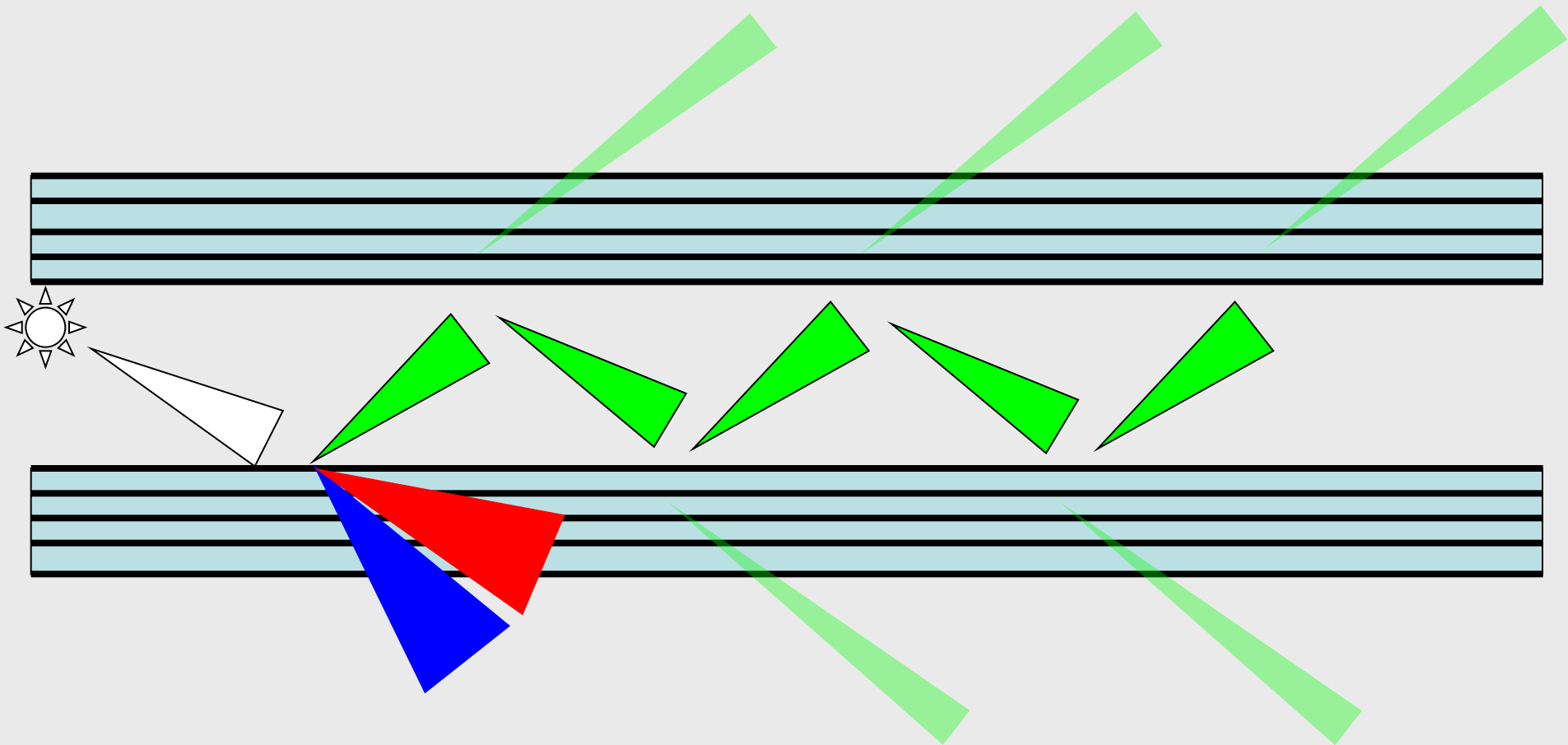

Photonic Crystal Fiber textiles – merging multilayer interference films with fiber optic textiles, and much more ...

Multilayer interference film

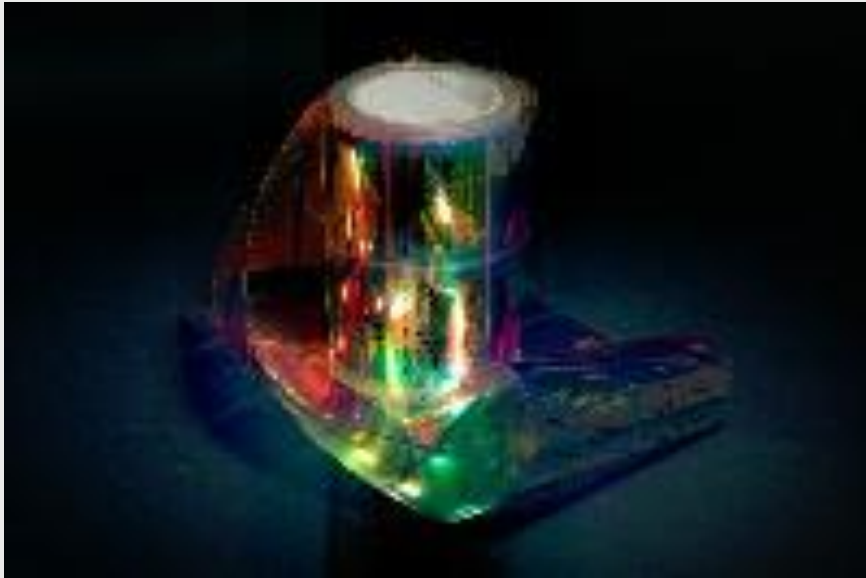

Fiber optic textile

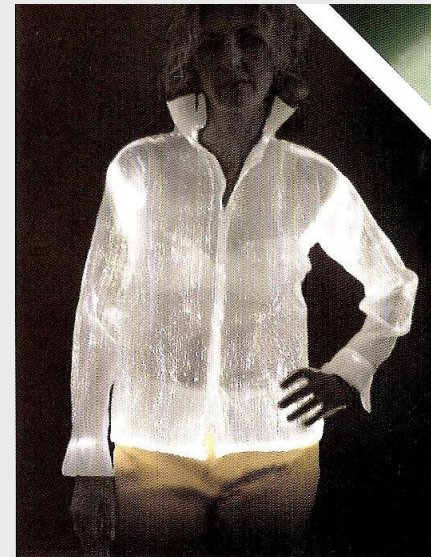

+

- No need for mechanical deformations for light extraction from the fibers
- Use of a single white light source for color applications
- Color on demand fibers without colorants
- On demand fiber luminosity by geometry design
- Color changing passive fibers

Prototype III. Reflection of directed light (no guided light)

Karma Chameleon project with the Hexagram center J. Berzowska, Concordia University



Prototype III. Reflection of directed light (no guided light)

Karma Chameleon project with the Hexagram center J. Berzowska, Concordia University

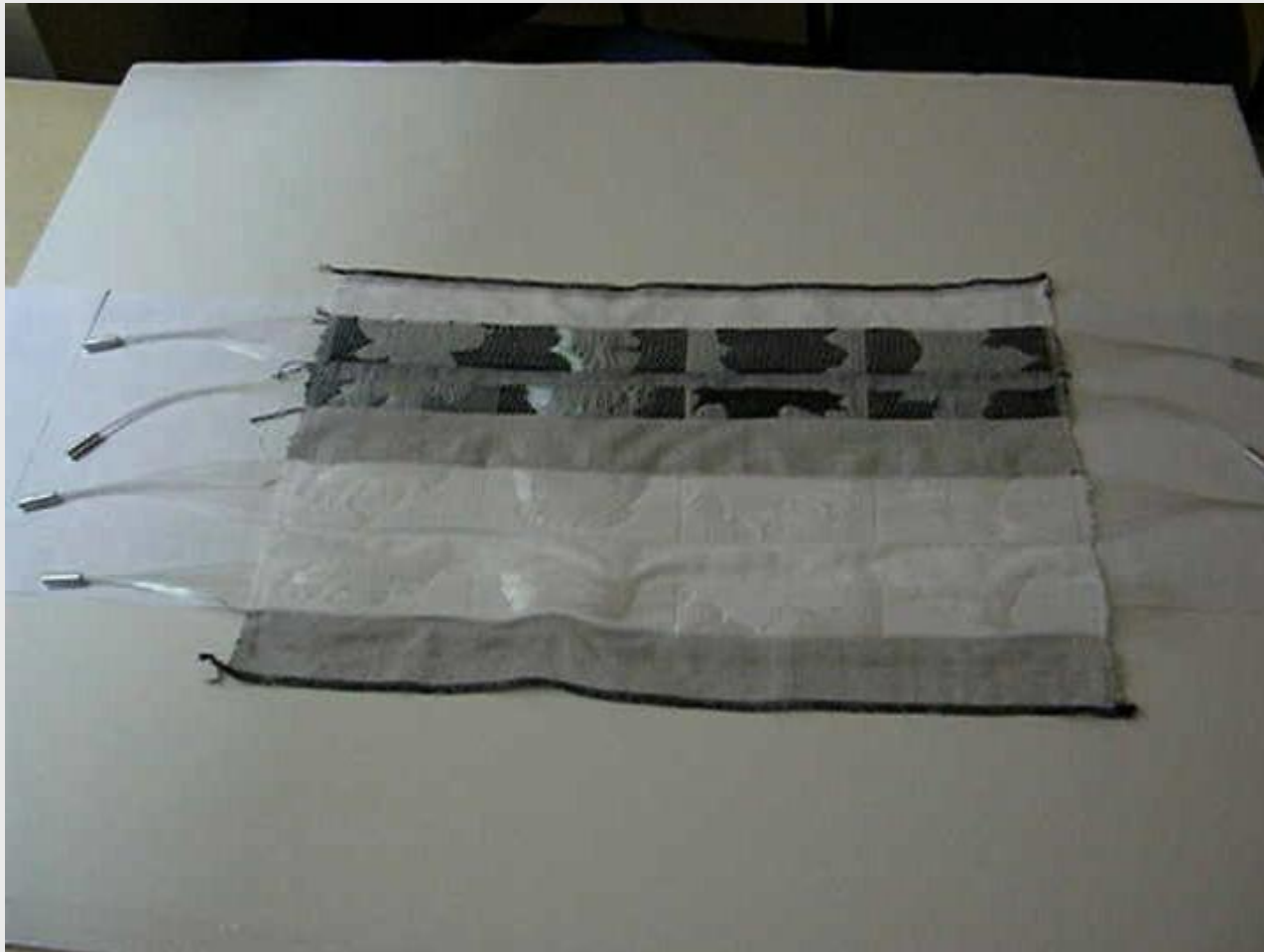

Prototype III. Emission of guided light. Switching patterns

Karma Chameleon project with the Hexagram center J. Berzowska, Concordia University

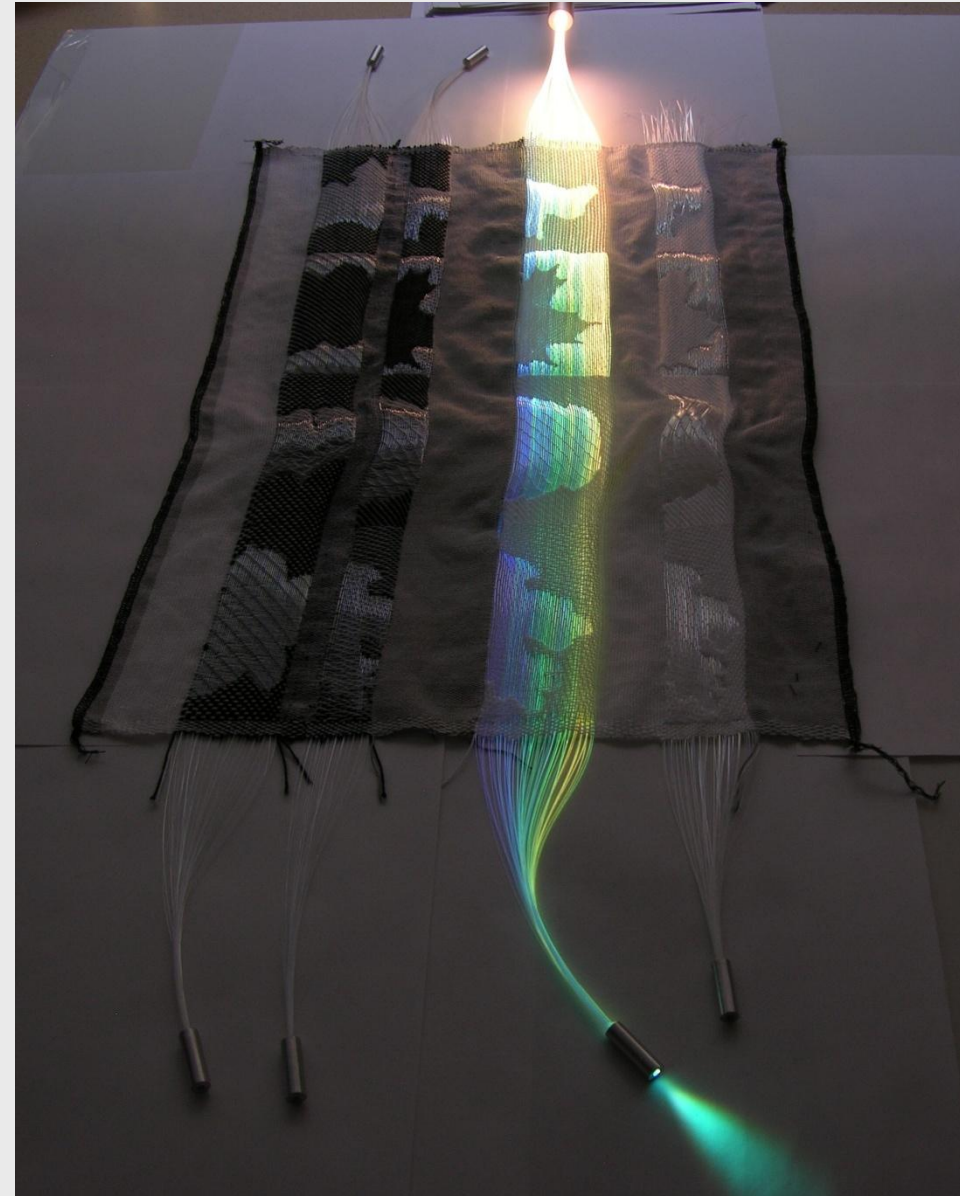
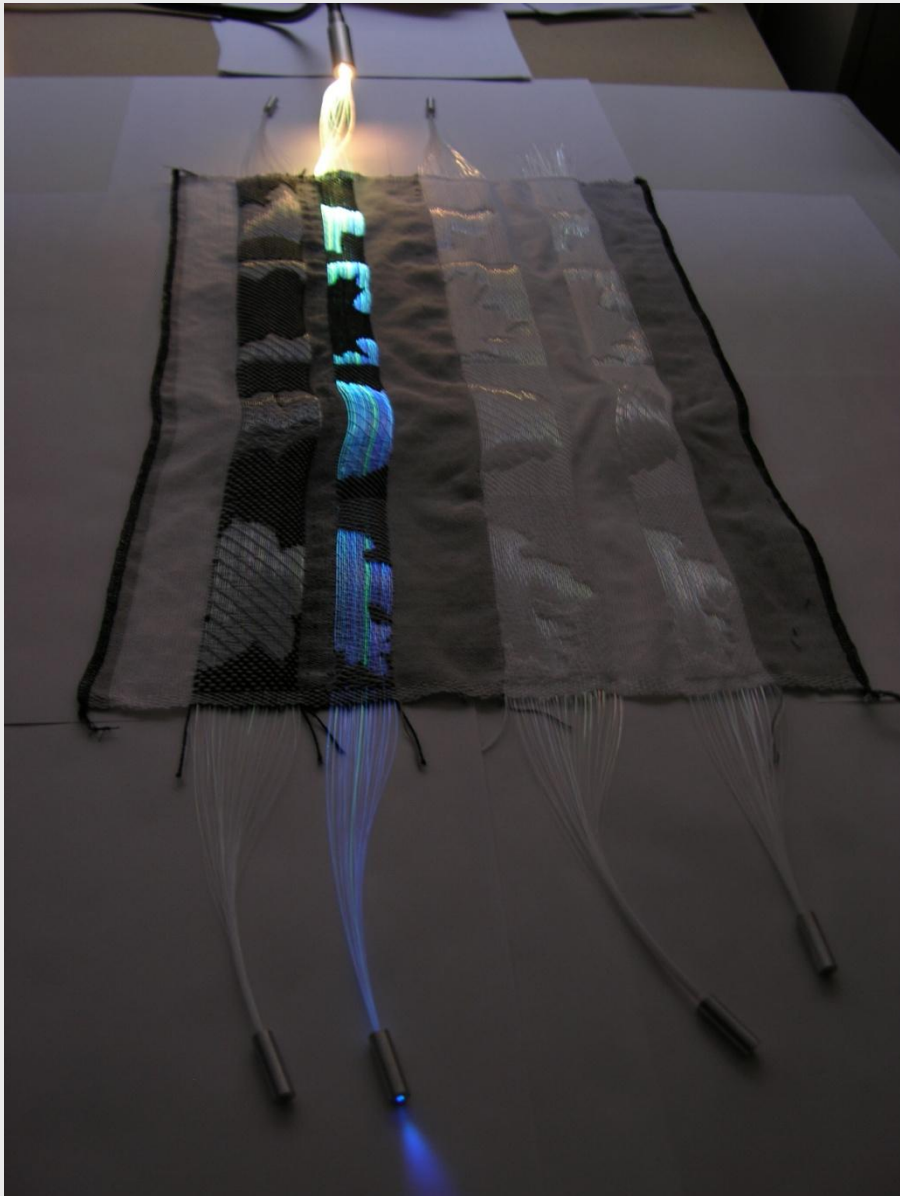

Prototype III. Emission of guided light

Karma Chameleon project with the Hexagram center J. Berzowska, Concordia University

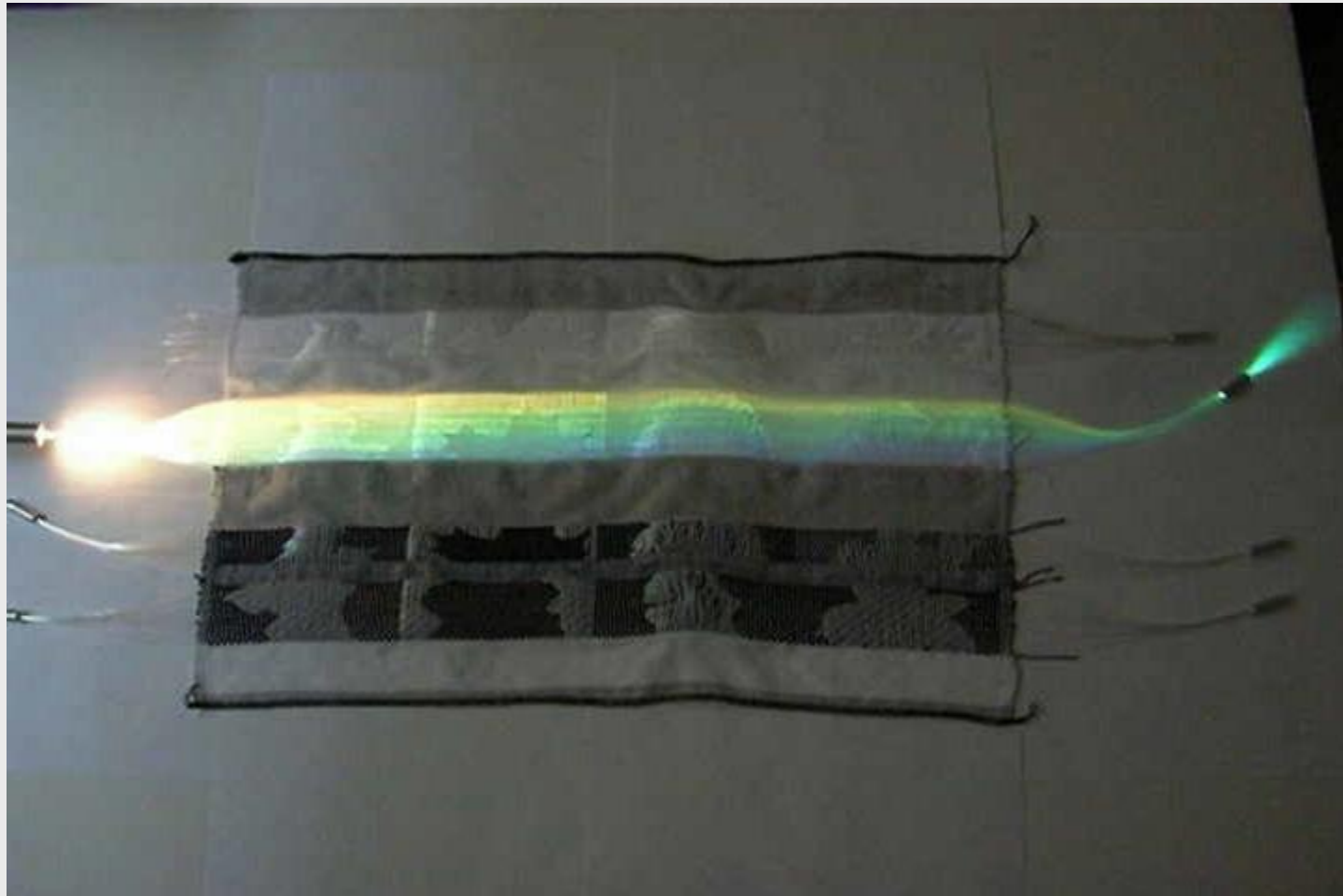

Applications of photonic textiles

Woven lighting panel

Karma Chameleon project with the Hexagram center J. Berzowska, Concordia University



A woven modular architectural animated lighting wall panel, with photonic band-gap fibers.

Paper-based illuminators

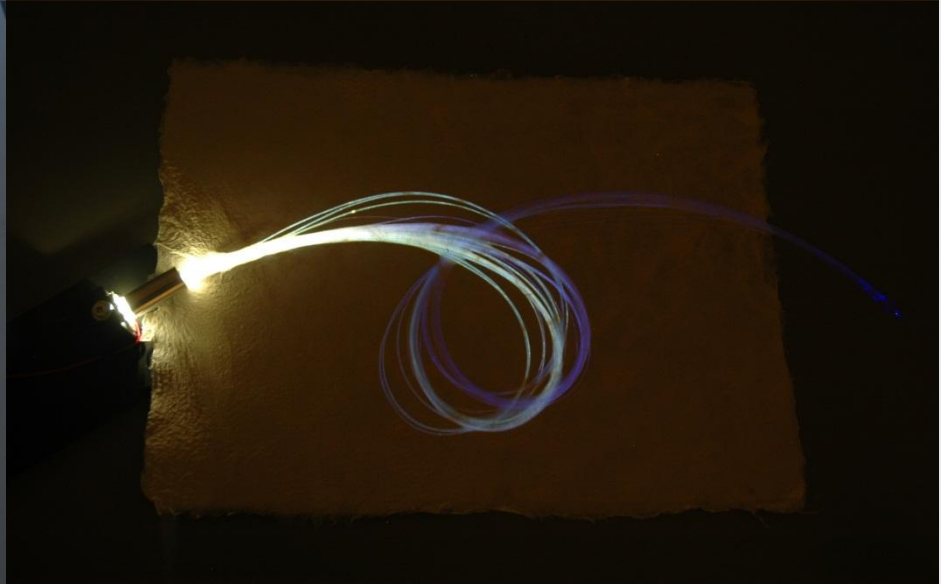
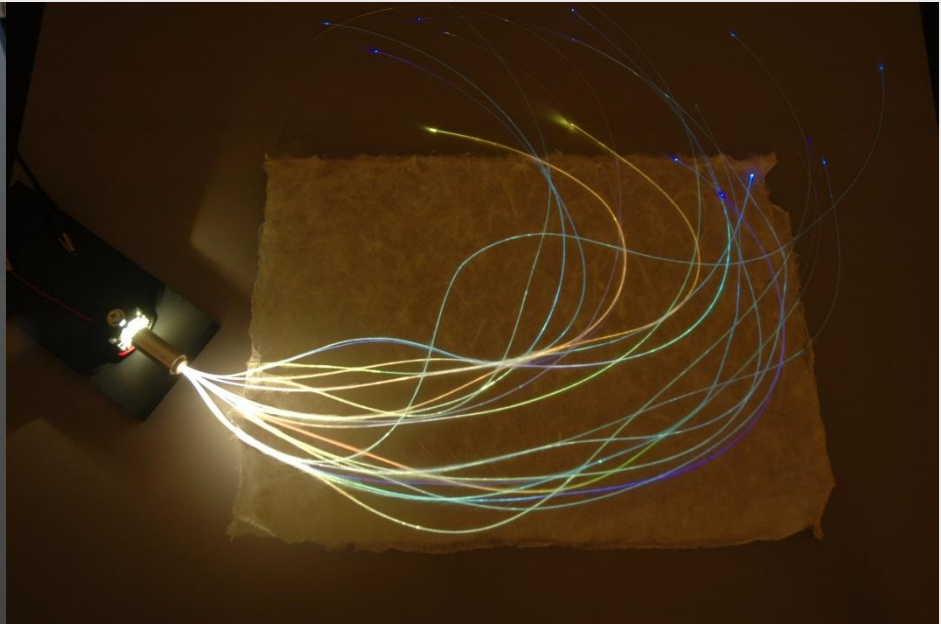
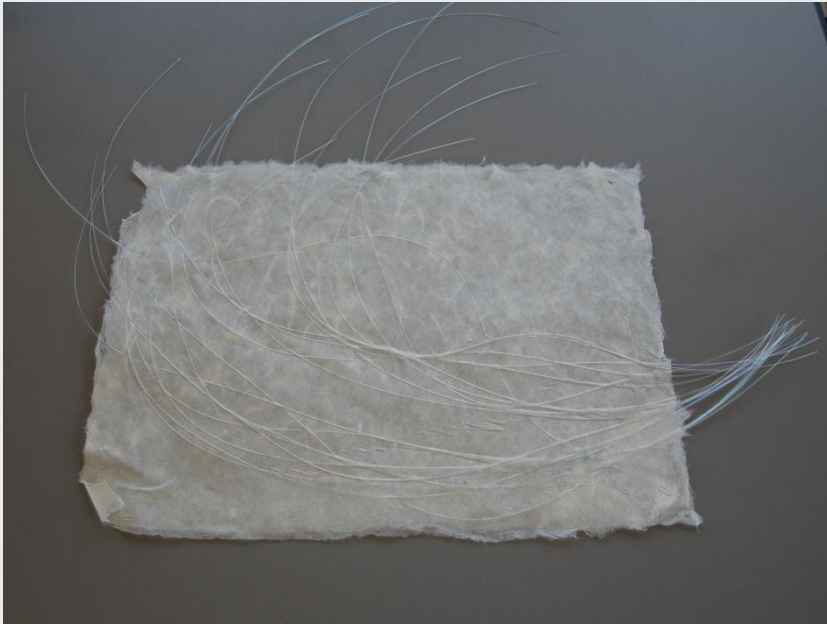

Apparel with changing appearance: application in the road security ware

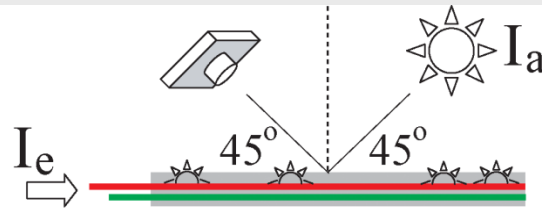

(a) $I_a = \max$

(b) $I_e = \max$

$I_e = \max$ ←

→ $I_e = 0$

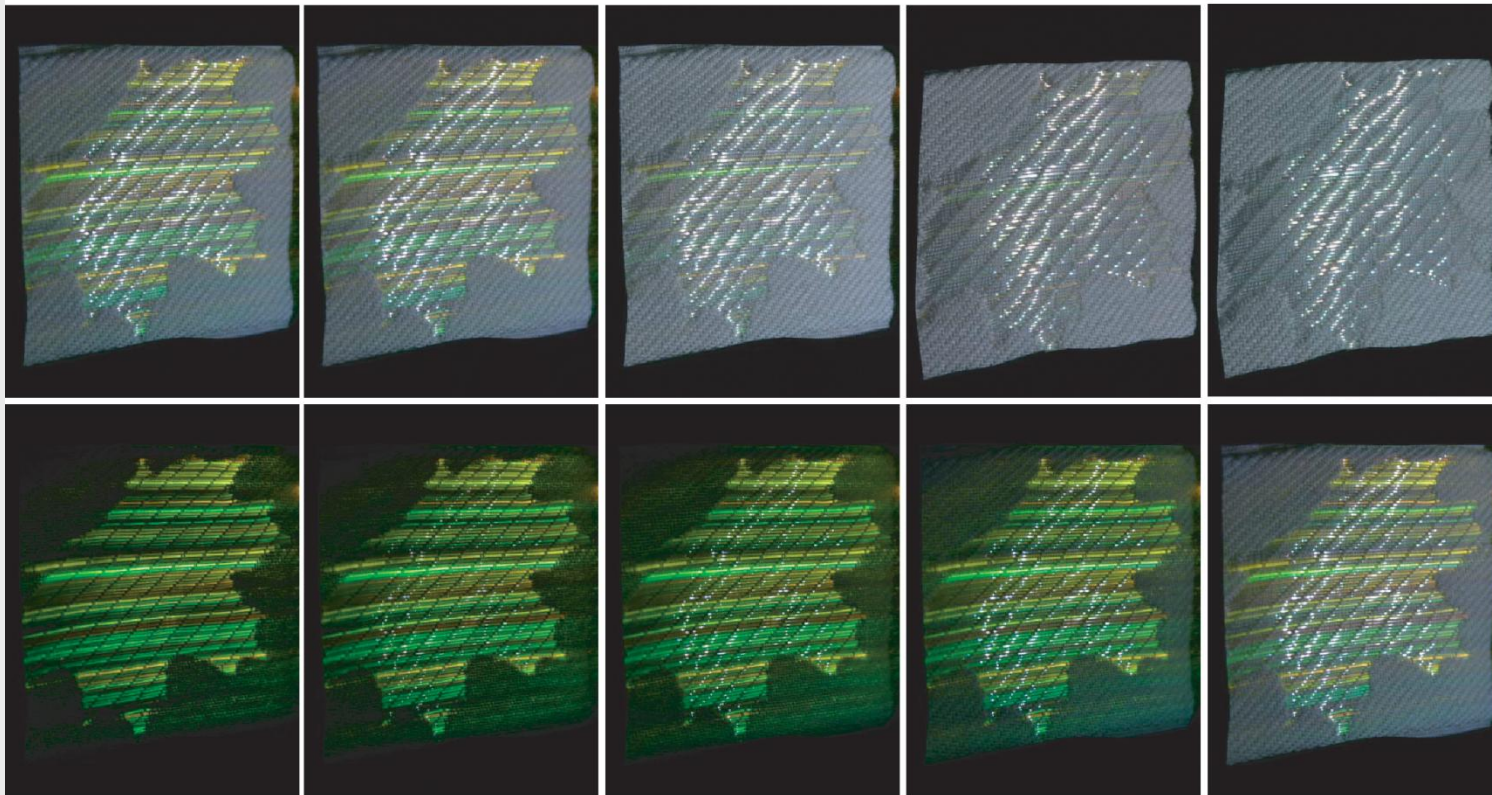

$I_a = 0$ ←

→ $I_a = \max$

Apparel with changing appearance: application in the road security ware

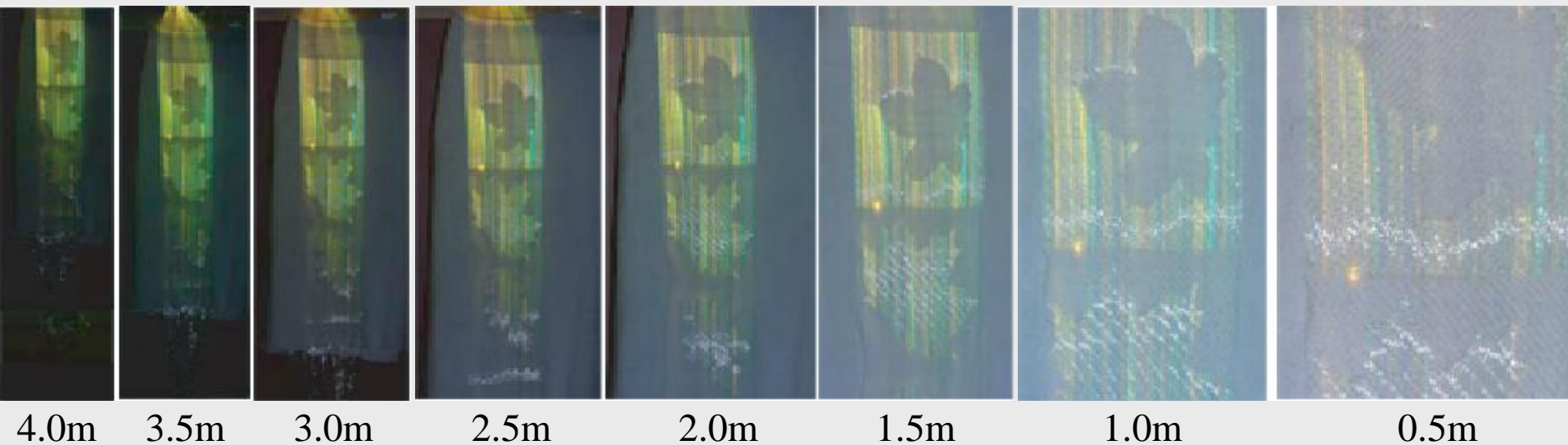
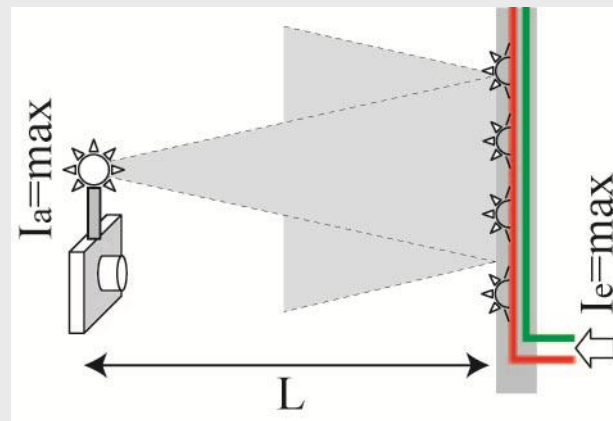

Pleats - an interactive garment

Karma Chameleon project with the Hexagram center J. Berzowska, Concordia University

An interactive garment with integrated silk & photonic band-gap fiber woven strips concealed within pleats.

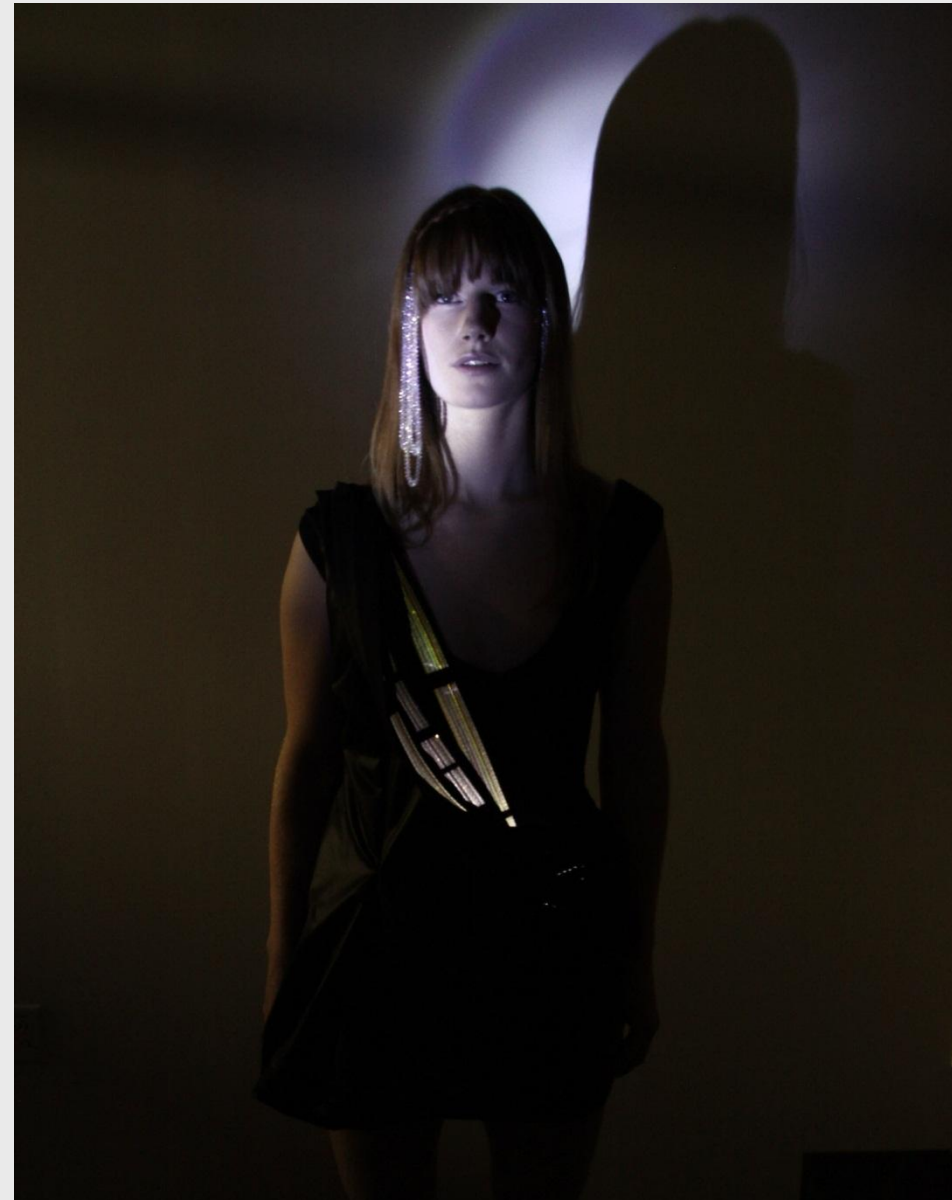

Pleats - an interactive garment

Karma Chameleon project with the Hexagram center J. Berzowska, Concordia University



Smart textiles under development in our group

- Photonic textiles
- Actuator/sensor textiles
- Energy storage textiles

Sensing textiles

Demonstration set-up:

- Analog-to-Digital-Converter board with embedded function generator at 1 kHz
- PC

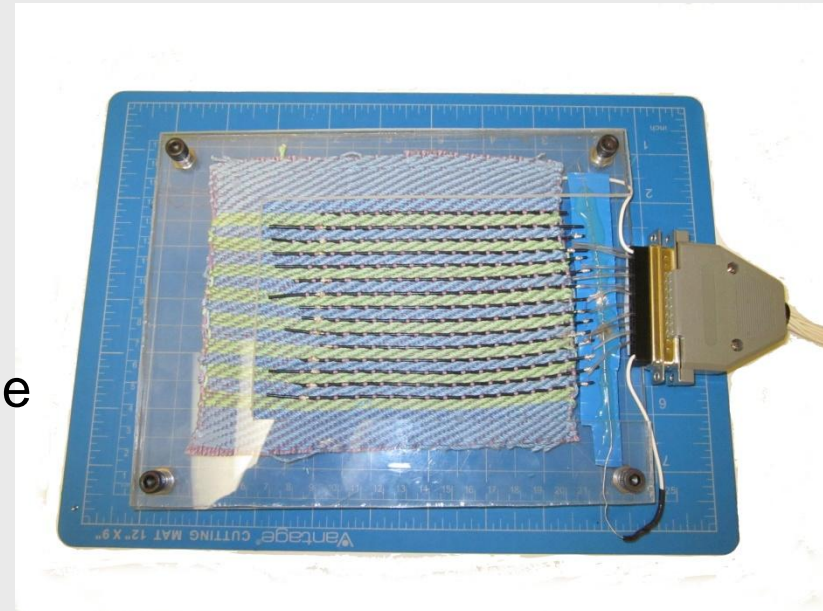

Types of touch-sensors

Resistive sensing

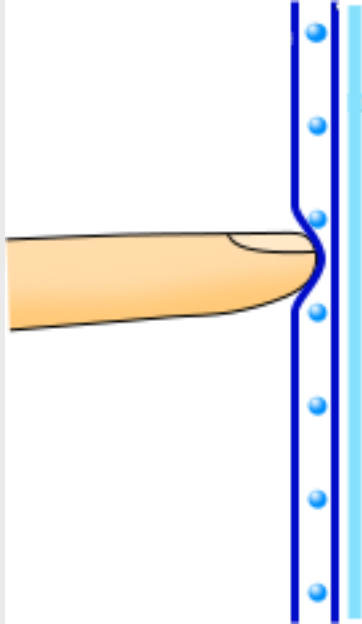

Pressure of the touch
creates a contact

Capacitive sensing

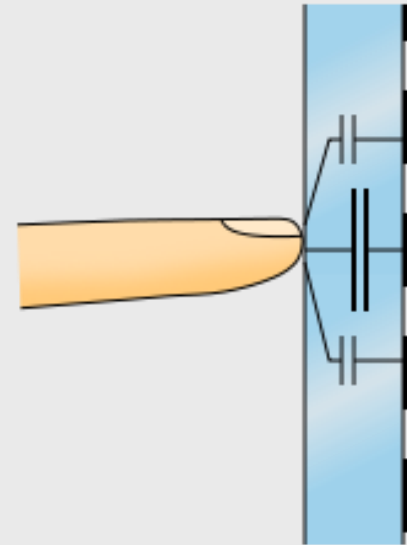

User's body capacitance changes
total capacitance of the sensor

High capacitance fiber concept

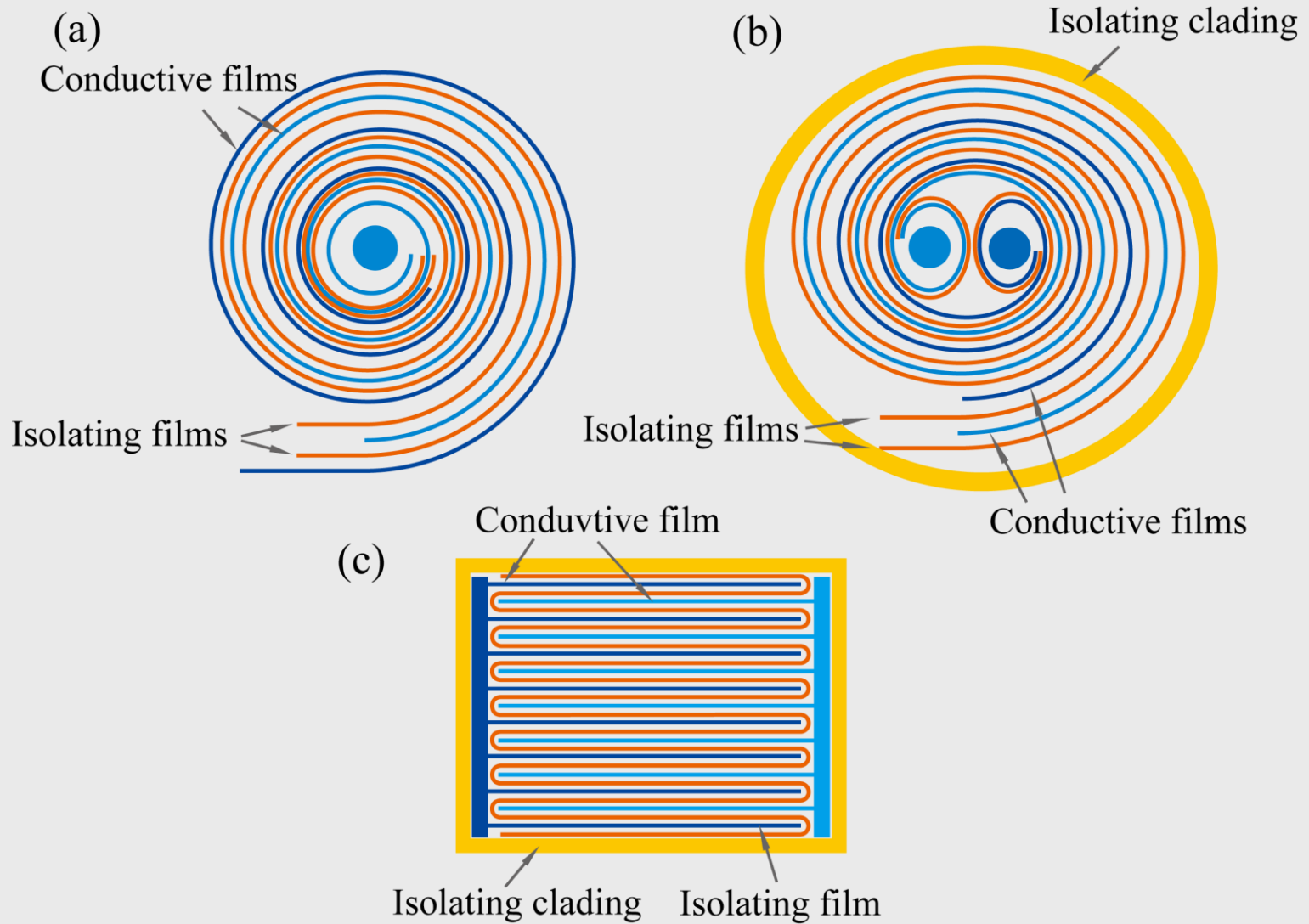

Co-rolling

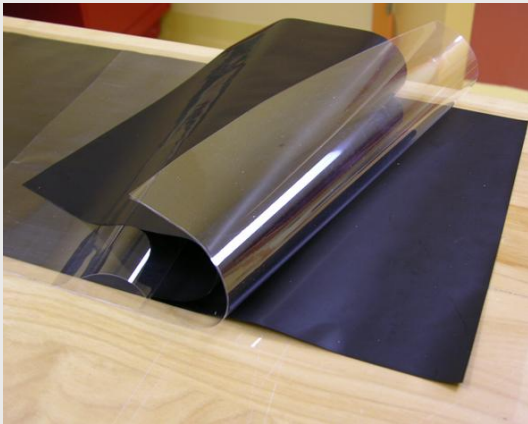

Consolidation

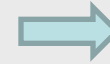

Heat drawing



- Soft and lightweight
- Diameter: 0.65-1mm
- Capacitance: 60-100nF/m
- Resistivity: $\sim 5\text{k}\Omega\cdot\text{m}$



Capacitor fiber connectorization

Preforms

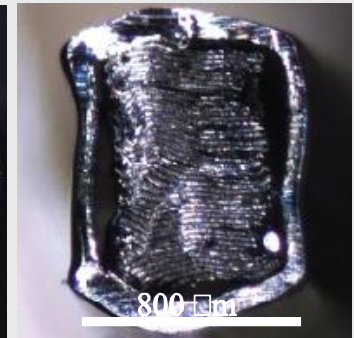
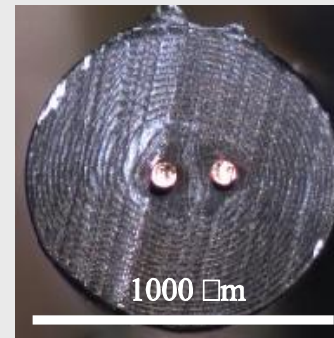
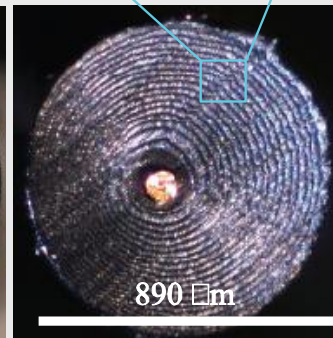
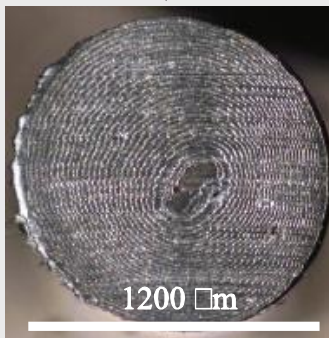
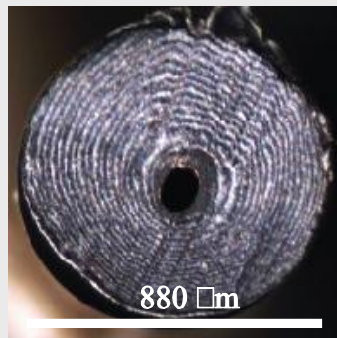
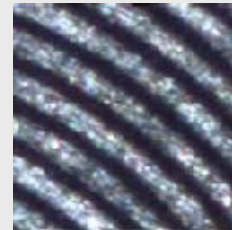
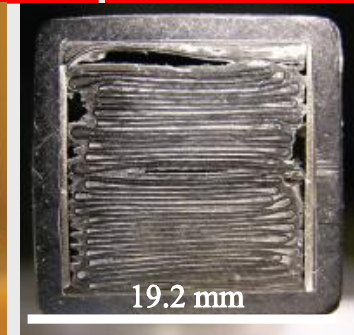
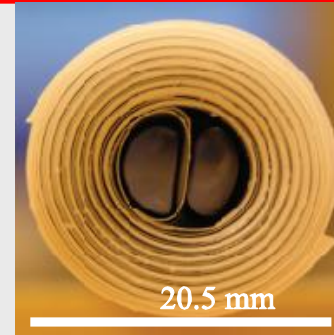
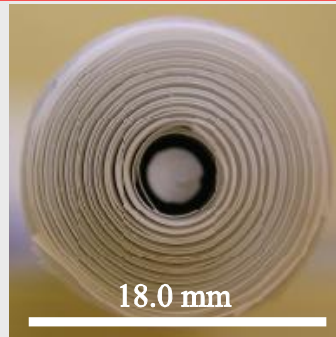

(a)

(b)

(c)

(d)

(e)

Fibers

J.F. Gu, S. Gorgutsa, and M. Skorobogatiy ["Soft capacitor fibers using conductive polymers for electronic textiles,"](#) Smart Mater. Struct., vol. 19, 115006 (2010)

J.F. Gu, S. Gorgutsa, and M. Skorobogatiy ["Soft capacitor fibers for electronic textiles,"](#) Appl. Phys. Lett., vol. 97, 133305 (2010)

Integration of soft capacitor fibers into textiles

weaving

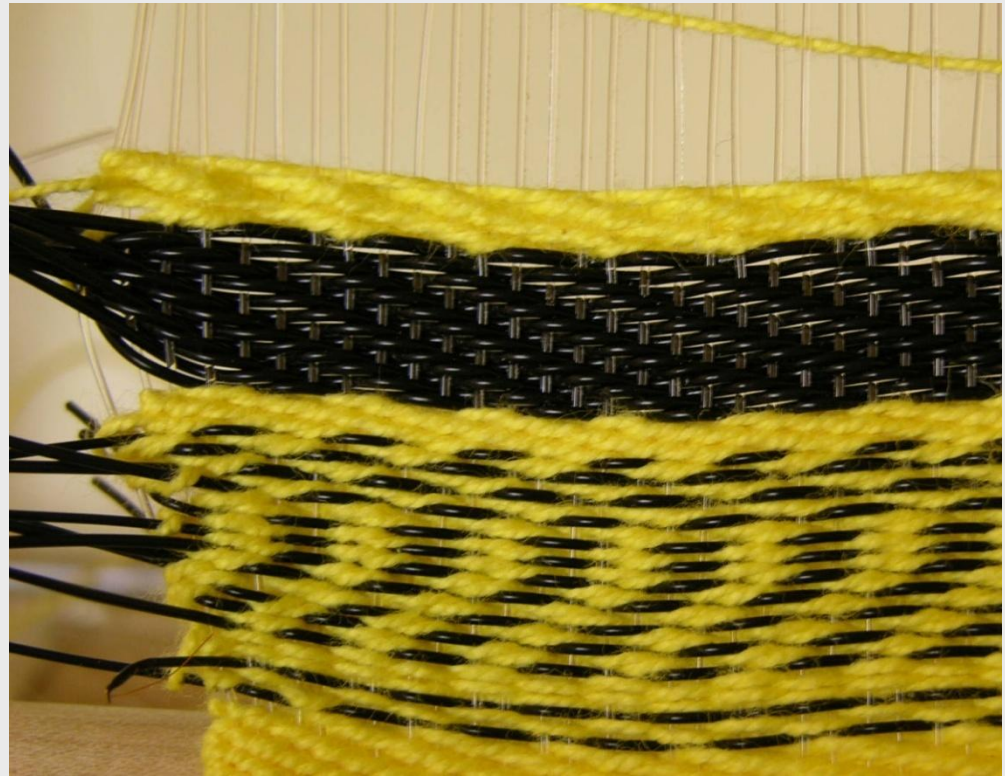

Capacitor fiber as a touch-sensor

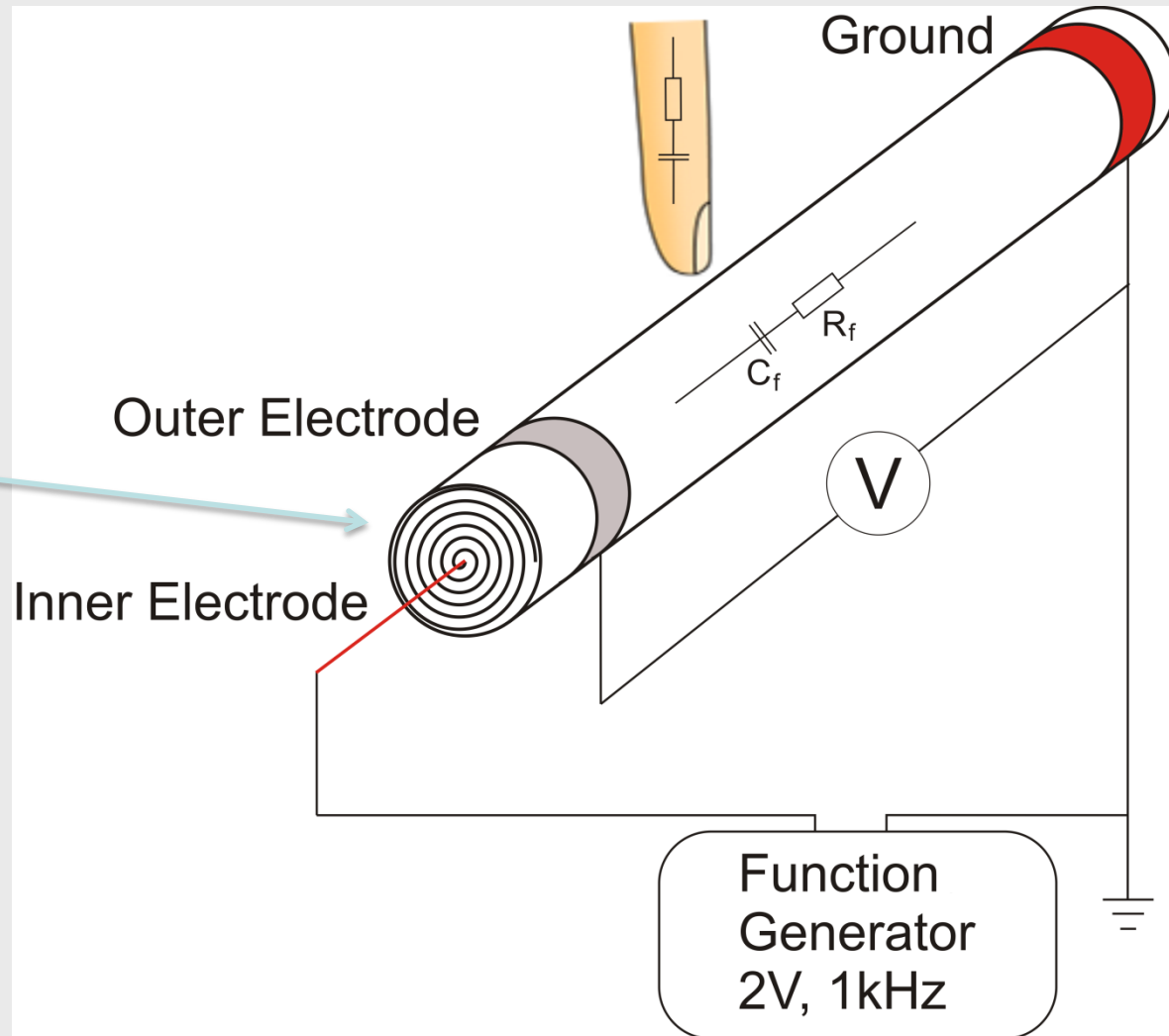
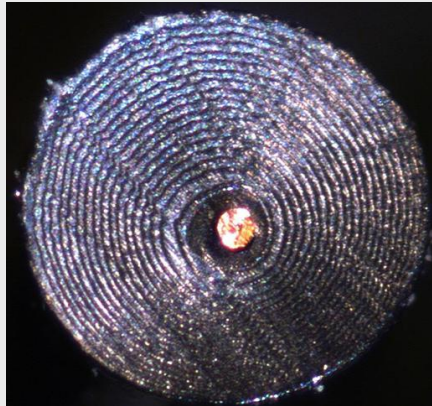

User's touch effects voltage distribution

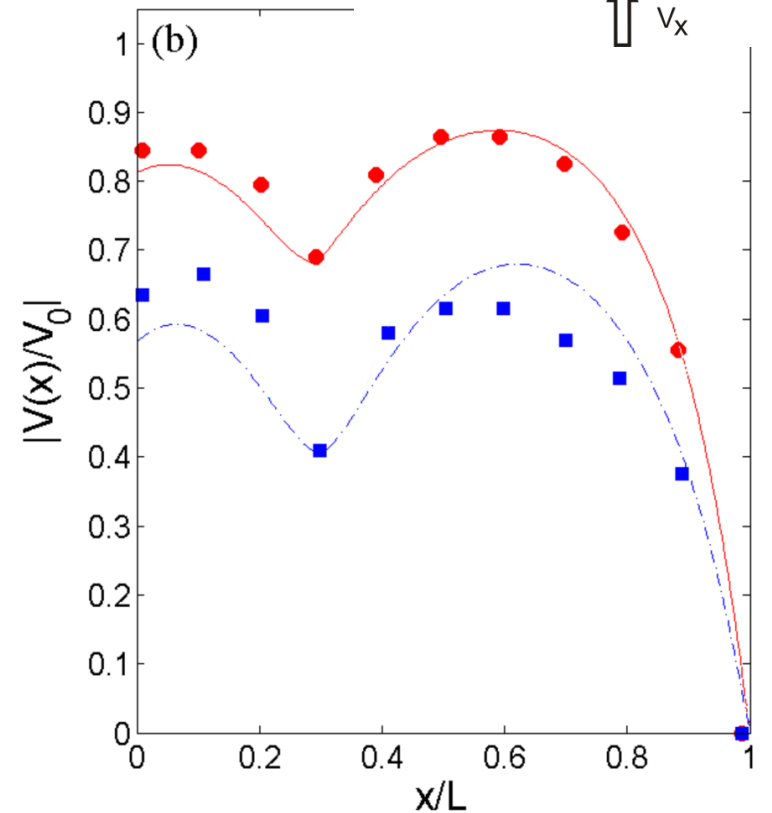
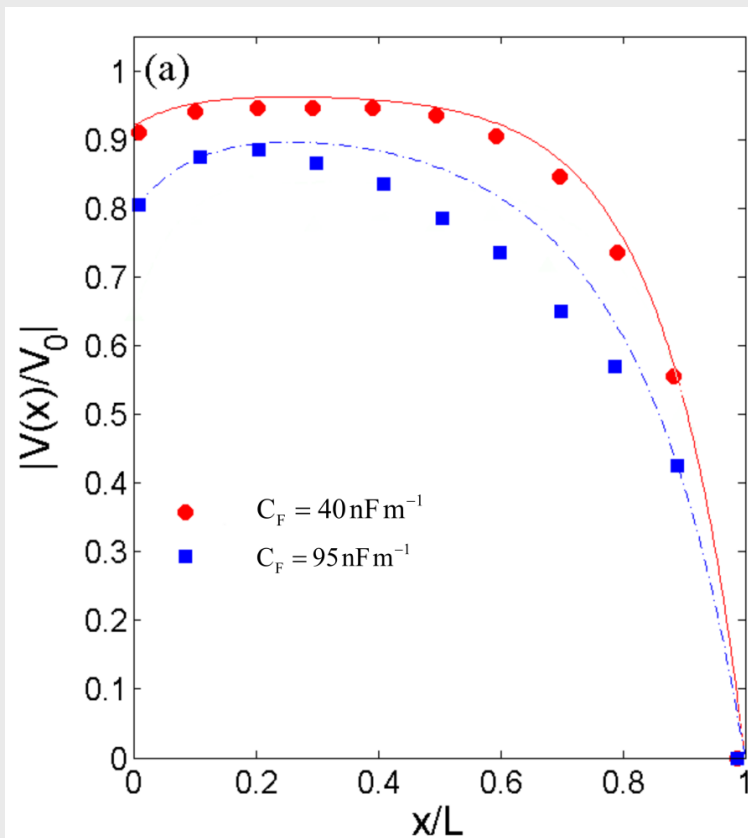
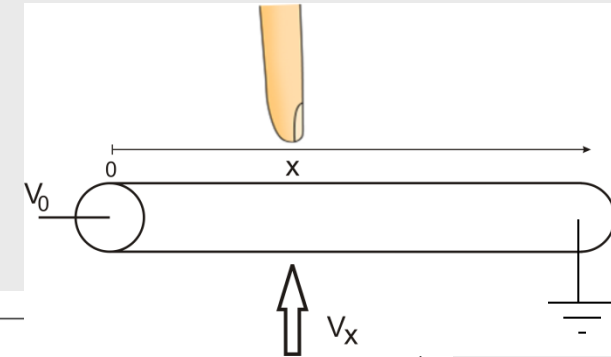
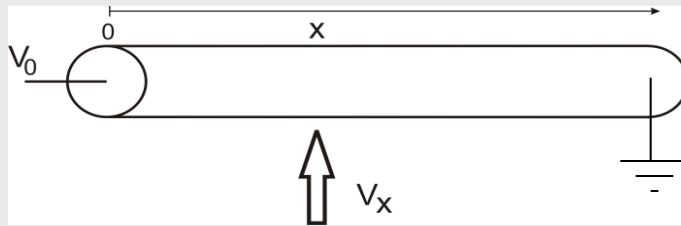

Comparison of the performance of two fibers with different capacitance per unit length.

Parameters that affect touch sensing performance

- Fiber length
- Capacitance per unit length
- Volume resistivity



$$\omega = \frac{1}{R C}$$

High capacitance (100 nF/m) and volume resistivity result in relatively low operating frequency ~ 1kHz

Integration of the capacitor fibers into the textile

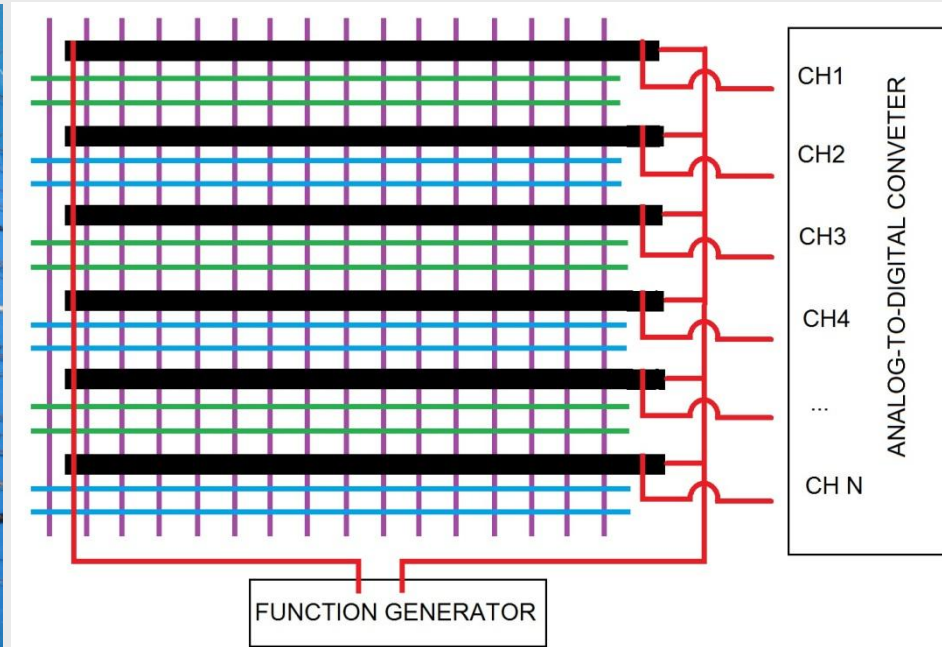
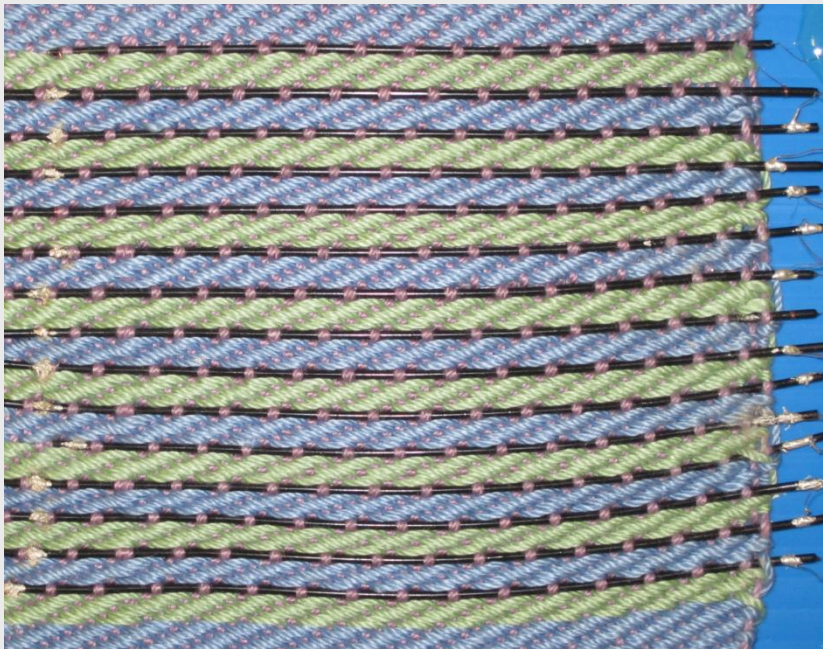

Woven 2D sensing textile with integrated 1D array of the capacitor fibers and its schematic representation.

Textile-based touch pad in action



Smart textiles under development in our group

- Photonic textiles
- Actuator/sensor textiles
- Energy storage textiles

Soft Li-ion battery stripes woven into textile and connectorized with conductive yarns (M. Skorobogatiy, February 2011)

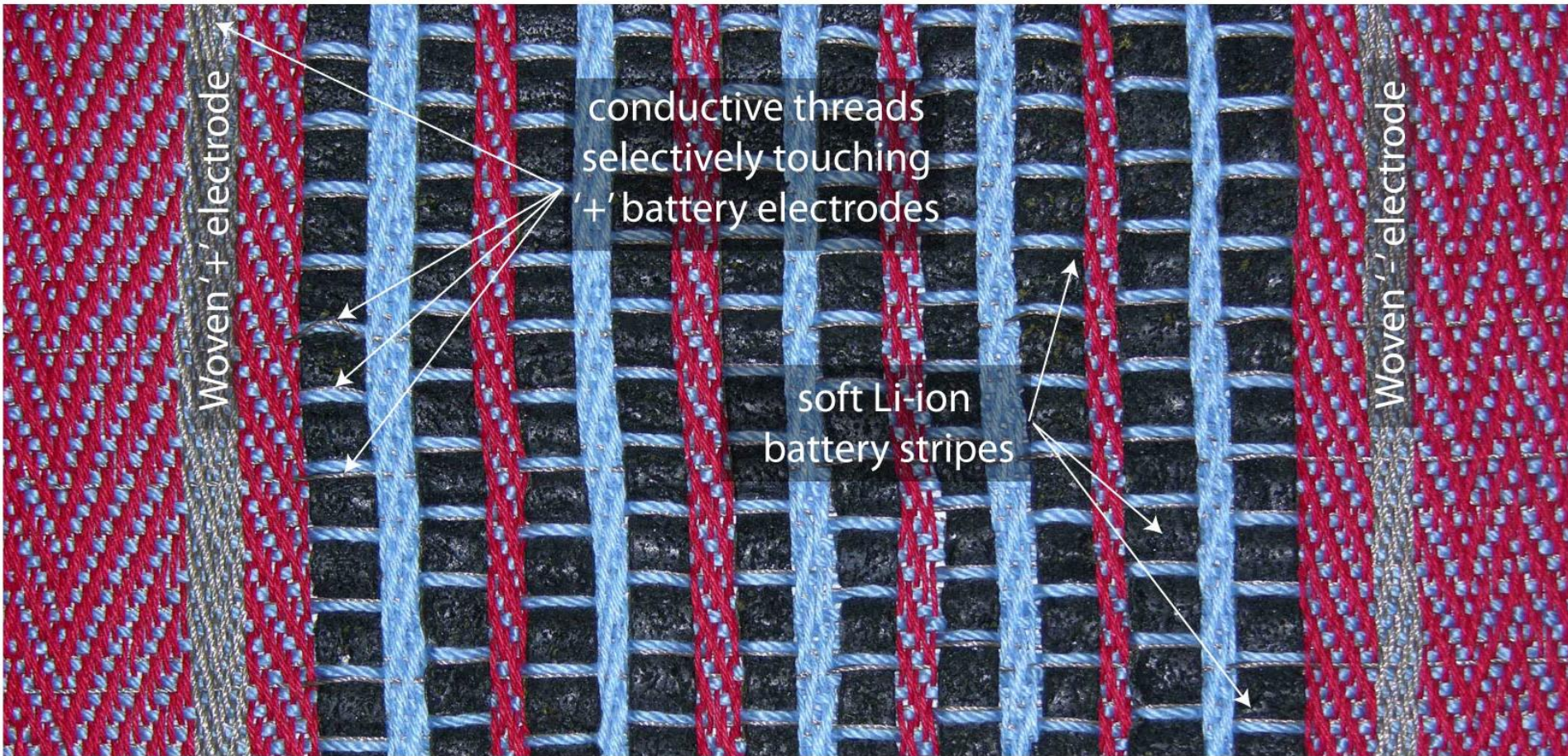

Y. Liu, S. Gorgutsa, C. Santato, and M. Skorobogatiy [“Flexible, Solid Electrolyte-Based Lithium Battery Composed of \$\text{LiFePO}_4\$ Cathode and \$\text{Li}_4\text{Ti}_5\text{O}_{12}\$ Anode for Applications in Smart Textiles,”](#) Journal of The Electrochemical Society, vol. 159 (4), pp. A349-A356 (2012)

Polymer batteries: structure and materials

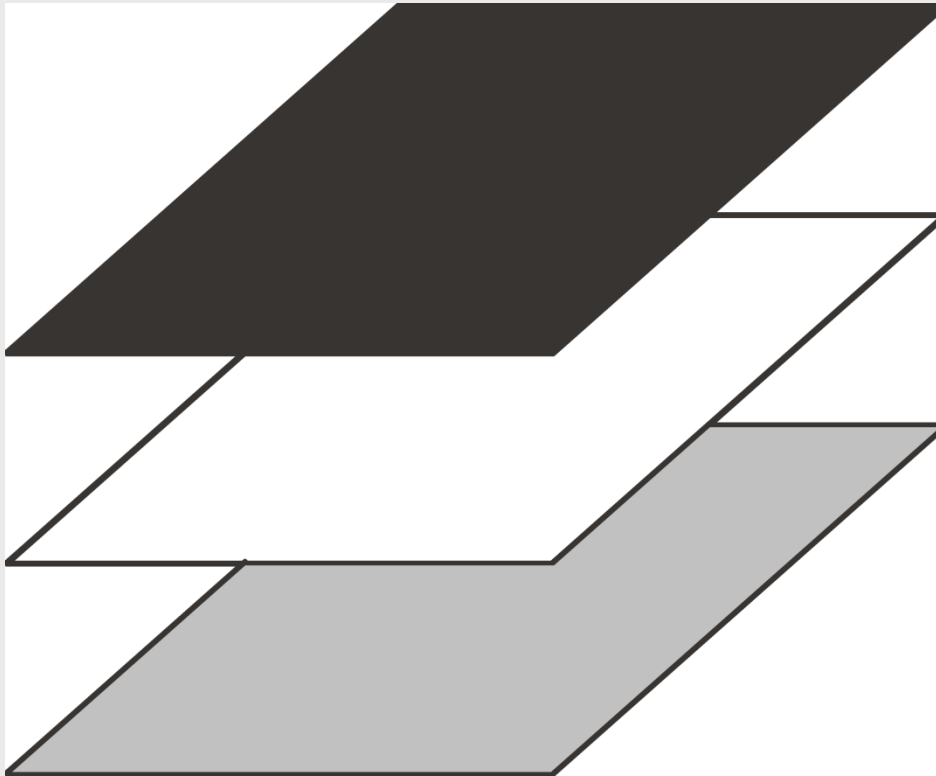

Anode: PEO (polyethylen oxide)
polymer electrolytes
+ Lithium Titanate + Carbon black

Electrolyte: PEO + Lithium Iodide

Cathode: PEO+
+ Lithium Iron Phosphate
+ Carbon black

Flexible, fully polymer - no liquid electrolyte is needed!

Fabrication process

1. Preparation of the liquid polymer solutions

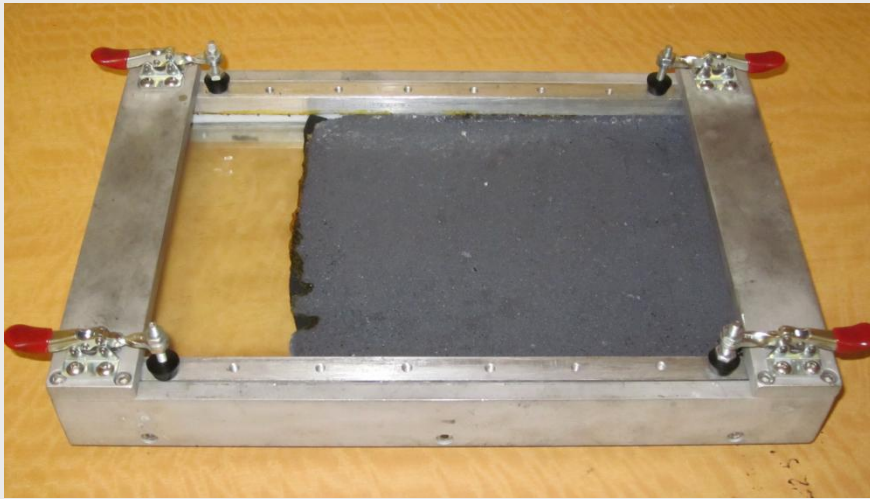

2. Evaporation



3. Consolidation of the separate layers into the battery.

Incorporation into textile

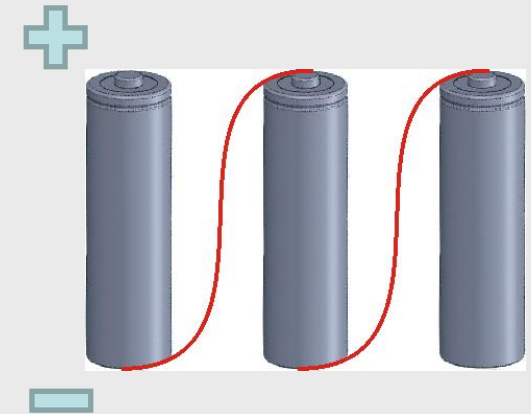

Each stripe is a 0.6V battery itself!

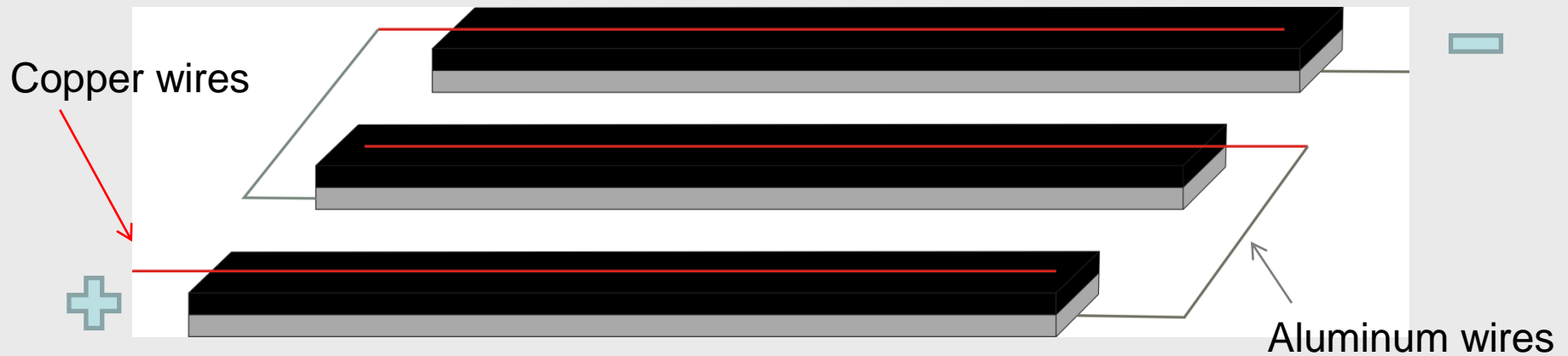

Battery textile sample

3V LED

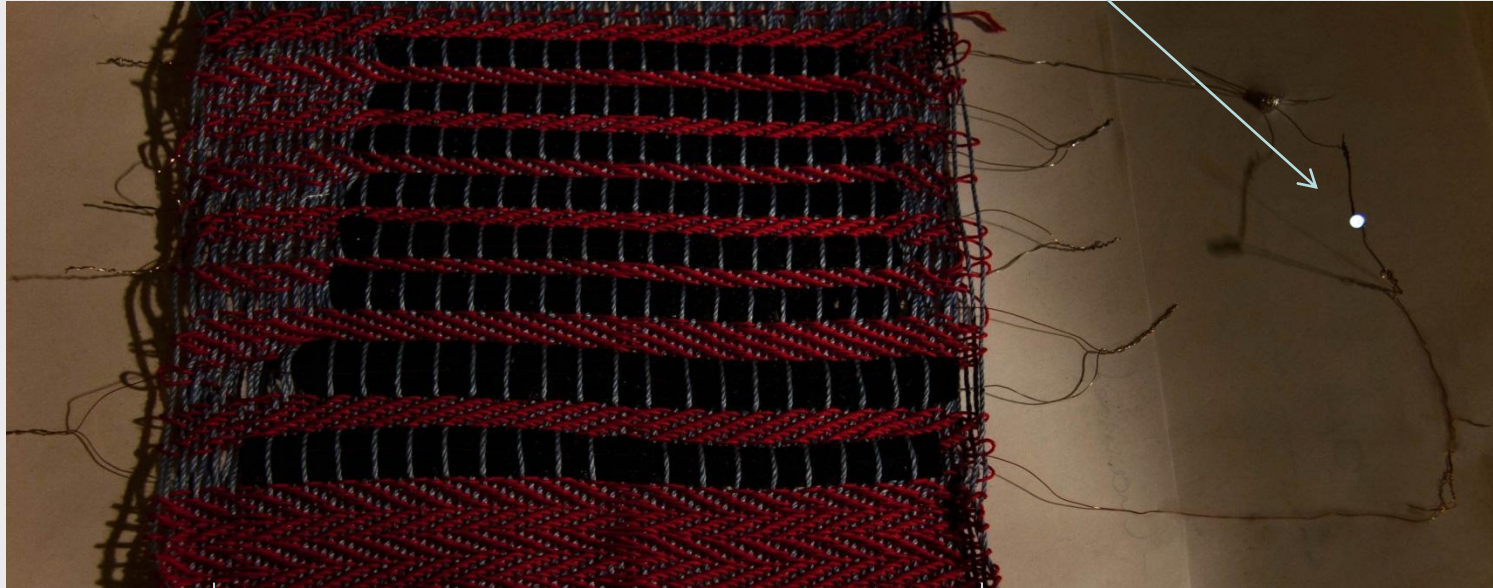

**8 polymer battery strips incorporated into a woven textile
give enough power to light a led**

Thank you

Maksim Skorobogatiy,
Professor and Canada Research Chair,
École Polytechnique de Montréal, University of Montreal, Canada
www.photonics.phys.polymtl.ca

Karma Chameleon project with Professor **Joanna Berzowska,**
Hexagram research center, Concordia University and XS Labs
www.hexagram.org
www.xslabs.net/
<http://www.xslabs.net/karma-chameleon/>

Acknowledgements

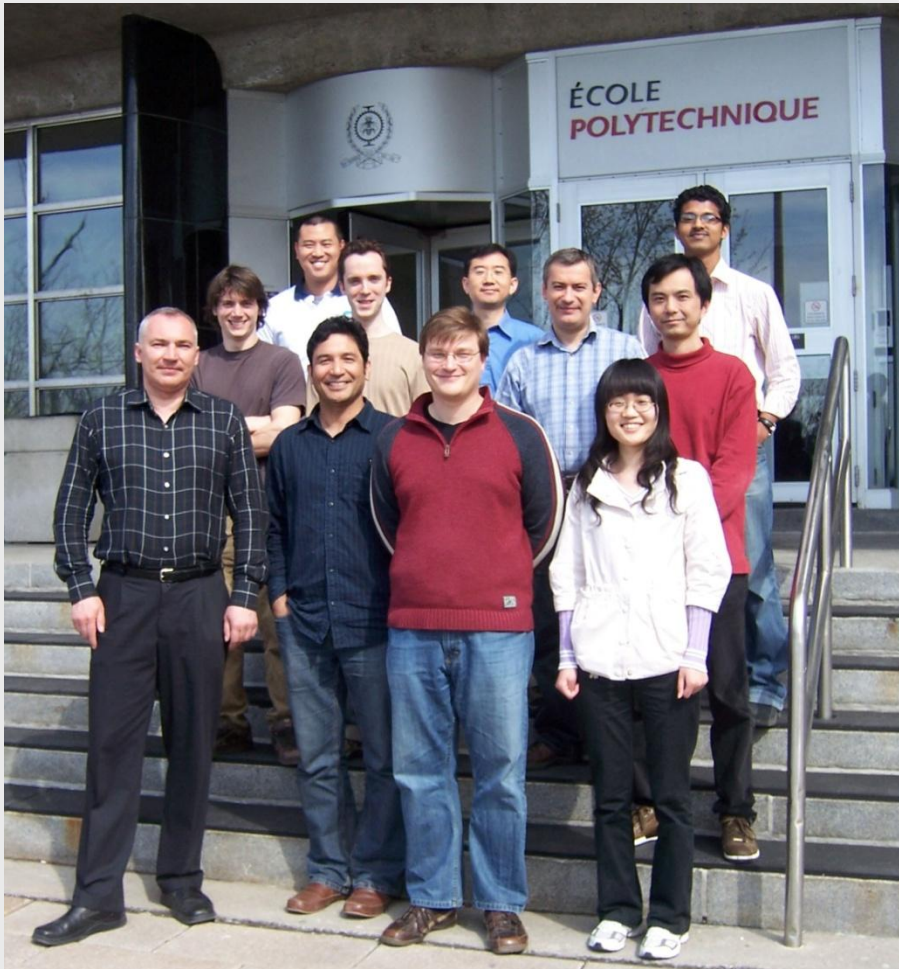

- Prof. C. Dubois
- Prof. T. Ishigure (Keio U)
- Prof. J. Berzowska (Concordia U.)
- Researcher A. Kabashin

- Res. Assoc. N. Guo
- Res. Assoc. E. Pone
- Post. Doc. J. Feng Gu
- Post. Doc. F. Desevedavy
- Post. Doc. L. Shi
- PhD A. Dupuis
- PhD A. Hassani
- PhD A. Magorova
- PhD S. Gorgutsa
- PhD Q. Hang
- PhD B. Ung
- MSc B. Gauvreau

- Canada Research Chair Foundation
- The Natural Sciences and Engineering Research Council of Canada
- Fonds Québécois de la Recherche sur la Nature et les Technologies
- Canadian Institute for Photonics Innovations



Canada Research
Chairs